

Annex C. Adapters specification

High performance Pt100 adapter

Four-wire connection to the sensor eliminates the voltage drop in the wires, see Figure 15. Two channels of the ADC are used. The sensor resistance is given by the ratio of the ADC readings for ch1 and ch0 times value of the RS resistor. Therefore the performance is essentially given by the quality of the resistor RS. A high stability type is recommended. Typical values are for 3.9KΩ for RC and 100Ω (0.1%) for RS. The resistor RC determines the current through the sensor. It should be scaled such that the full-scale range of the ADC for the full temperature range required is below 100mV and that the input current of the ADC can be neglected (~100pA). Calibration has to be done by exchanging the sensor with a known stable high-precision resistor. The motherboard has place for four adapters of the type shown in Figure 16 per 16 channel inputs.

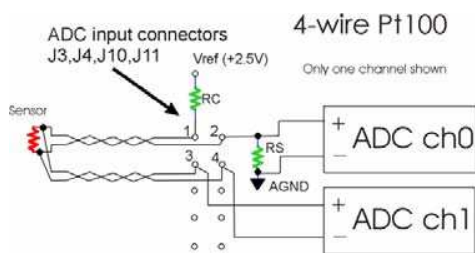

Figure 15: Principle of the 3-wire resistance measurement

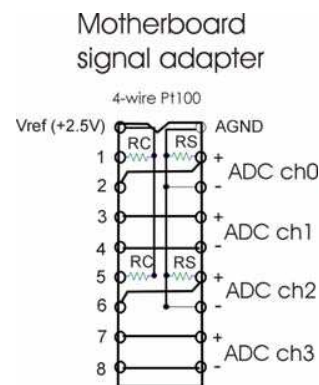

Figure 16: Plug-in adapter for 2 channels

The equation to be used for the sensor comes from the equation below:

$$R(t) = R_0(1 + at + bt^2)$$

This can be solved to give the value for the temperature, t , from the equation:

$$t = \frac{-a + \sqrt{a^2 - 4b(1 - R(t)/R_0)}}{2b}$$

The values of a and b are given by the manufacturer of the sensor. Typical values for these constants are $a = 3.9083 \times 10^{-3}$ and $b = -5.775 \times 10^{-7}$.

R_0 is the value of the resistor at 0°C (for a Pt100, this is 100).

$R(t)$ is the resistance of the sensor at the temperature being measured.

The equation for $R(t)$ is given by:

$$R(t) = \frac{ch1 \times R_s}{ch0}$$

where $ch1$ is the value read by channel 1 (as shown in Figure 15)

$ch0$ is the value read by channel 0 (as shown in Figure 15)

For the 4-wire sensors, it is not important whether the values read are in μV or in ADC counts, as the ratio of the two channels is taken.

Resistance Temperature Detector (RTD) sensors

RTD sensors (for example NTC 10k or Pt10000) but also other sensors like strain gauges and position sensors where the resistance changes as function of the parameter can be measured with this adapter. The principle of 2-wire measurements of resistive sensors is shown in Figure 17. The

resistance of the connection wire will influence the accuracy of the measurements but this effect can be reduced by calibration. The input current of the ADC has also to be taken into account. The circuit should be calibrated by replacing the sensor with a known precision resistor. About 10mA per input connector (16 channels) is available from the V_{ref} in Figure 17. The V_{ref} is generated with the help of a stable precision operational amplifier from the same reference voltage as is used by the ADC. The adapter is shown in Figure 18. The value of the resistors in Figure 18 for 10 kohms@25° C NTC resistors is chosen to be 1 M Ω . This permits measurements of temperatures in the range from -5° C to >100° C at a constant ADC input voltage range of 100 mV.

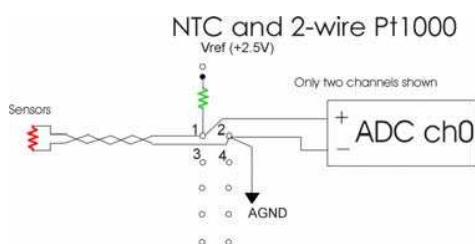

Figure 17: Principle of the 2-wire measurements

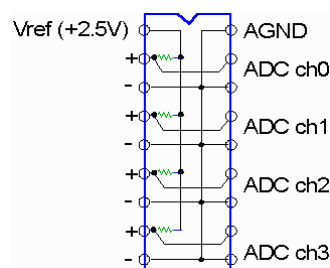

Figure 18: Plug-in adapter for 4 channels

The equation for the 2-wire Pt sensor is the same as for the 4-wire sensor. However, the calculation for the resistance $R(t)$ is different and is given by:

$$R(t) = \frac{ch0 \times R_A}{(2.5 - ch0)}$$

where $ch0$ is the voltage measured by the channel
 R_A is the value of the resistor on the adapter

If the ELMB has been set to give ADC counts (and not μV) or is an older ELMB that does not have the ability to send values in μV then the value from the channel reading must be converted to volts by the following formula:

$$ch0_{volts} = \frac{ch0_{counts} \times Range_{volts}}{65535}$$

where $ch0_{volts}$ is the result value in volts
 $ch0_{counts}$ is the ADC count as returned by the ELMB for the channel
 $Range_{volts}$ is the currently set voltage range for the ELMB's ADC (e.g. for 100mV, this is 0.1)

For an NTC sensor, the equation is given below:

$$T = \frac{1}{A + B(\ln(R(t))) + C(\ln(R(t)))^3}$$

The values of A , B and C are given by the manufacturer of the sensor. Typical values for these constants are $A = 9.577 \times 10^{-4}$, $B = 2.404 \times 10^{-4}$ and $C = 2.341 \times 10^{-7}$.

$R(t)$ is the resistance of the sensor at the temperature being measured as calculated above for the 2-wire Pt sensor.

Differential attenuator

The Crystal Semiconductor ADC CS5523 used in the ELMB with the input multiplexer can measure voltages up to the range from -2V to 5V. The common mode range is -0.15 V to 0.95V on the three lowest voltage ranges and -2V to 5V in the other ranges. With the help of a differential attenuator the input ranges of the ADC can be extended see Figure 19. The ratios of $R1$ to $R2$ and $R3$ to $R4$ should be